

Aussie FIRE SMART

Aussie Pumps
You deserve it!

AUSSIE FIRE CHIEF

Aussie Pumps
5 YEAR
pump end
warranty

Summer
2017

Out-performs & out-features all others!

POWERED by
HONDA™



Genuine Honda
GX series 5.5HP

Metal caps
& chains

Separate
replaceable
suction flange

BIG 2"
suction port

Big belly body
means FAST priming

BIG drain plug

Steel skids with
anti-vibration mounts



Performance... QP205SE/GX160

Max flow 450 lpm

Max head 75m

5.5HP Honda GX series

Self primes FAST from 7.6m

The biggest impeller
in the business - 2.5 times
heavier than competitors ...
more water & more pressure

Huge 7 1/2" diameter

Aussie Pumps

www.aussiepumps.com.au

Also available in diesel drive



YANMAR

Model Numbers: **Aussie Fireman**
Aussie Fire Chief
Aussie Fire Captain
Aussie Fire Captain Plus

Aussie "Mr T"
Aussie QP305

FIVE YEAR PUMP END WARRANTY ON ALL AUSSIE QUIK PRIME PUMPS

The Aussie Fire Chief, the Fire Captain and "Mr T" super high pressure twin impeller fire pumps are regarded as the world's finest lightweight portable high pressure pumps. The Fire Chief has won significant contracts both within Australia and in export markets.

Extraordinary performance, quality components and ease of serviceability makes the Aussie Fire Chief is the choice of farmers and professional fire fighting authorities around the world.

Aussie Fire Chief (QP205SE)

Designed to out-perform and out-feature all other portable fire fighting pumps, the Aussie Fire Chief offers significant quality features.

These include a huge 7½" diameter, one piece impeller that weighs 2½ times more than impellers in other brands. The big belly body provides large water passages allowing more water to get through the pump and significantly aiding performance.

The pump will produce flows of up to 450 litres per minute and heads as high as 75 metres. The basic engine is a genuine Honda 5.5HP four stroke engine with oil alert, low oil protection, cast iron cylinder bore in conformance with tough international environmental emission standards. The Fire Chief comes with anti vibration mounts, steel skids and handle as standard.

Aussie Fireman (QP-2S)

Taking it's design principles from the Aussie Fire Chief, the Aussie Fireman is a smart choice for light use applications where the engine is not required to run continually for long periods. It uses a Honda GP series engine with 1 year engine warranty ... more details page 5.

Aussie Fire Captain (QP205S)

The Captain comes in the same configuration as the Aussie Fire Chief but with heavy duty steel roll frame instead of steel skids. Supplied with anti vibration mounts, the frame provides extra protection for the unit and added ease of transport.

Aussie Fire Captain Plus (QP205SL)

A big single impeller Aussie Fire Chief pump but with a 6.5HP, 9HP or 13HP Honda four stroke petrol engine all supplied with oil alert and cast iron cylinder bore. Electric start option available on all models.

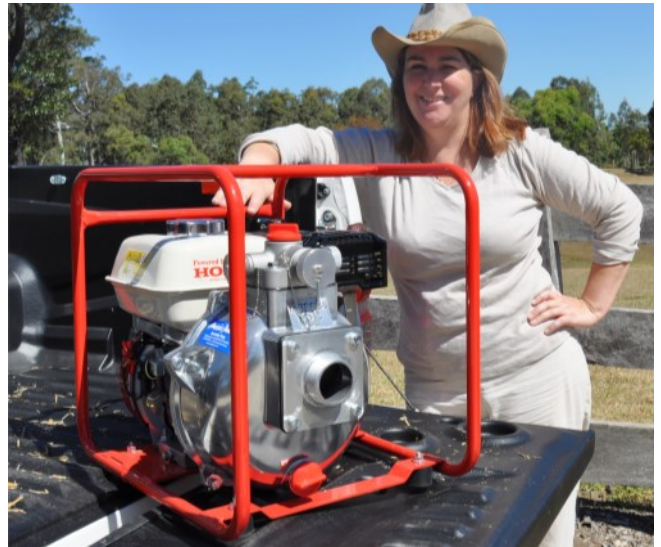

Standard equipment includes full heavy duty roll frame with pump performance figures of up to 510 litres per minute flow, 75 metres head.

Aussie "Mr T" Twin Impeller Fire Pump (QPT-205SLT)

The Aussie "Mr T" is the final extension of development of the Aussie Fire Chief. It is a heavy duty twin impeller pump but with a difference!

The huge, closed vane dual impellers create a combination of high pressure and high flow that is unmatched, max head is 95 metres, max flow is 480 litres per minute.

The Aussie "Mr T" twin impeller range is available with 9HP or 13HP Honda four stroke engine power as standard equipment with electric start option available. "Mr T" is available with 2" x 2" ports, 2" x 3-way ports (1½", 1", 1") or with 3" x 3".

NEW Mr T 13HP electric start version now available with long range fuel tank (18 litres) ... Runs for up to 4.5 hours under load in extreme heat.

Aussie QP305SL 3" High Pressure Pump

The 3" version of the Aussie Fire Chief, the QP305SL is available in a wide range of options that provide flows of up to 510 litres per minute and heads as high as 68 metres.

Engine options include 5.5HP, 6.5HP, 9HP and 13HP Honda four stroke engines with oil alert and cast iron cylinder bore.



Five Year Warranty:

Aussie Quik Prime pumps carry a unique pump end five year warranty. The products are guaranteed to be free of faulty workmanship or material for a period of five years after the date of sale to the end user.

Only top quality genuine brand engines by reputable manufacturers are used.

A 3 year Honda GX engine manufacturer's warranty applies, supported by Honda's worldwide service network.

POWERED by **HONDA**



Quality
ISO 9001
SAI GLOBAL

FIVE YEAR PUMP END WARRANTY ON ALL AUSSIE QUIK PRIME PUMPS



Fire Chief

Applications:

- Fire fighting, mop up and general fire protection
- High pressure water transfer
- Spray irrigation
- Diesel fuel transfer
- High pressure spraying
- Sheep jetting
- Boom spraying
- Stock crate wash down
- Machinery wash down



Features

- Five year pump end warranty
- Lightweight portable
- Fast self priming from 7.6 metres
- Replaceable flanged suction port cover and discharge elbow
- Honda four stroke GX series petrol engines (3 year warranty). The Honda GP series engine carries a 1 year warranty
- Skids with rubber feet and carry handle as standard
- Full frame with anti vibration mounts (option for Fire Chief, standard on all other versions)
- Single piece, heavy duty closed impeller
- Three way outlet
- Big 2 inch inlet
- Big belly body
- Three way outlet has top quality metal caps with chains
- Big drain port
- Big integrated priming port
- Optional Viton seal and o-ring kit
- Optional diesel engine & hydraulic drive options

Benefits

- » Great quality ... use with confidence
- » Weighs from only 23kgs
- » Ready to pump in minimum amount of time
- » Easily replaced if thread damaged, easy to service check valve without dismantling pump
- » Tried and proven with established service networks throughout the world
- » Feet absorb vibration - stable in operation
- » Protects pump, facilitates transport on site
- » Pumps more water at high pressure, saves fuel
- » Enables choice of plumbing sizes from 1" to 1 1/2 "
- » Lets more water into the pump
- » Larger water passages mean more water efficiency, lower fuel costs
- » Top quality, ensures outlet cap security
- » Fast, easy pump draining
- » Facilitates fast self priming
- » Enables pump to be used in some herbicide or insecticide spraying applications

Model	Engine Make	Type	Engine Model	HP	Max Head (m)	Max Flow (lpm)	Suct port	Discharge ports	Self primes to (m)	
Fireman (QP-2S)	Honda	4 Stroke	Petrol	GP160	5.5	60	450	2"	2x1", 1x1 1/2"	7
Fire Chief (QP205SE)	Honda	4 Stroke	Petrol	GX160	5.5	75	450	2"	2x1", 1x1 1/2"	7.6
Fire Captain (QP205S)	Honda	4 Stroke	Petrol	GX160	5.5	75	450	2"	2x1", 1x1 1/2"	7.6
Fire Captain Plus (QP205SL)	Honda	4 Stroke	Petrol	GX200	6.5, 9	75	510	2"	2x1", 1x1 1/2"	7.6
Mr T Twin impeller (QPT-205SLT)	Honda	4 Stroke	Petrol	GX270 or GX390	9, 13	95	480	2"	2x1", 1x1 1/2"	7.6
QP305SL	Honda	4 Stroke	Petrol	GX160, GX200, GX270 or GX390	5.5, 6.5, 9, 13	70	450	3"	3"	7.6
3" Mr T Twin impeller	Honda	4 Stroke	Petrol	GX270 or GX390	9, 13	95	500	3"	3"	7.6

NOTE: Aussie stock codes for QP pumps are determined by using the pump & engine model, for example QP205SL/GX200E is the 6.5HP Honda, electric start version of the QP205SL

* 13HP electric start Mr T available with the option of an 18 litre long range fuel tank

Model Numbers: Aussie Fireman
Aussie Fire Chief
Aussie Fire Captain
Aussie Fire Captain Plus

Aussie "Mr T"
Aussie QP305

FIVE YEAR PUMP END WARRANTY ON ALL AUSSIE QUIK PRIME PUMPS

Construction:

Front case	Marine grade aluminium
Volute	Marine grade aluminium
Back plate	Marine grade aluminium
Mechanical seal	Carbon/ceramic
Outlet	Marine grade aluminium
Casing bolts	Zinc plated steel
Check valve	Nitrile rubber
Priming & drain plugs	Polycarbonate
Casing, priming & drain plug o-rings	Nitrile rubber
Finish	Brushed aluminium
Impeller	Marine grade aluminium, closed type



Fire Captain



Mr T Twin Impeller

Optional Accessories:

- Heavy duty suction hose
- Fire fighting hose kits including deluxe hose kit with two 20 metre delivery hoses and fire fighting nozzles
- Coupling Kit
- Strainer
- Aussie Fire Cart for fast pump deployment

Dimensions:

Fire Chief

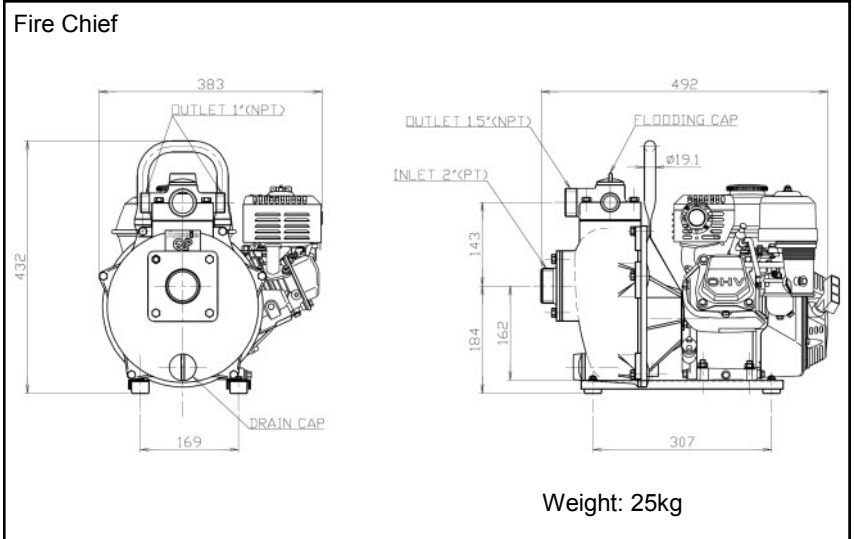

Weight: 25kg

Models with Roll Frames

	Width (mm)	Height (mm)	Length (mm)	Weight (kg)
Fire Captain (QP205S/GX160)	386	460	523	32
Fire Captain Plus (QP205SL/GX200FF)	386	460	523	35
Mr T Twin Impeller (QP205-TSLT/GX270)	510	610	710	57
Aussie QP305/GX200	386	460	523	35
3" Mr T Twin Impeller	510	610	710	57

Performance Curve:

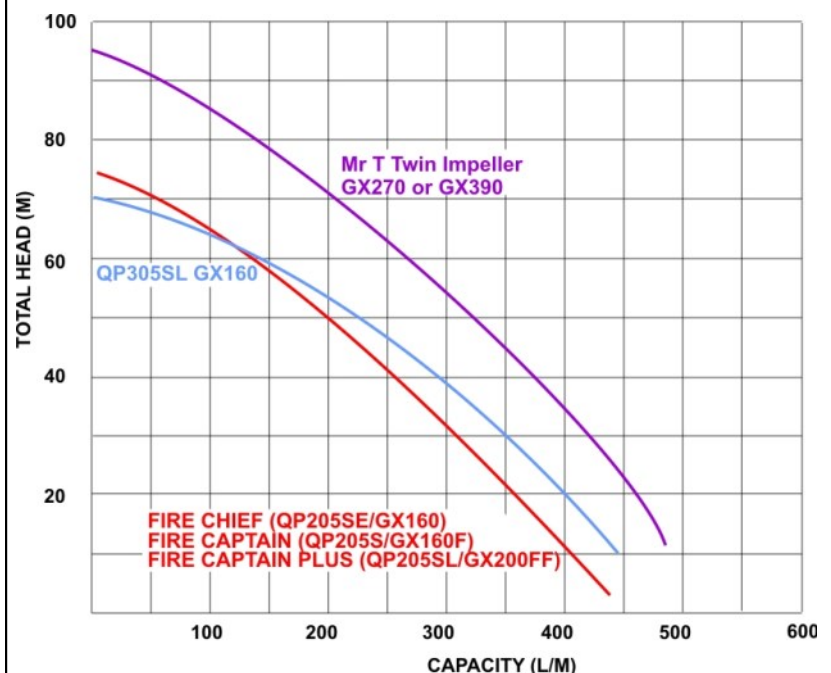



AUSSIE FIREMAN



Taking it's design principles from the Aussie Fire Chief, the new Aussie Fireman is a smart choice for light use applications where the engine is not required to run continuously for long periods.

- **Lightweight** ... portable hobby pump
- **Genuine Honda GP engine**
- **Primes fast** from 7.6 metres
- **Replaceable flanged** suction port & discharge ports ... easy to service check valve or change port size
- **FREE Skids** with rubber feet and carry handle
- Single piece, heavy duty closed impeller
- **Big 2 inch inlet**... 3 way outlet
- **Big belly body**... fast priming & extra performance
- **Big drain port**... quick draining
- **Easy access** priming port

HONDA PETROL - 1 year engine warranty

Inlet/Outlet	Model (s/code)	HP	Pump PSI	Max Head (m)	Max Flow (lpm)	Self primes to (m)	Carton size (mm) lwxhx	Boxed weight kg
2" inlet 3 way outlet (2 x 1" & 1 x 1 1/2")	QP2S (QP-2S/GP160)	5.5 (GP160)	85	60	450	7	400 x 490 x 410	21.5

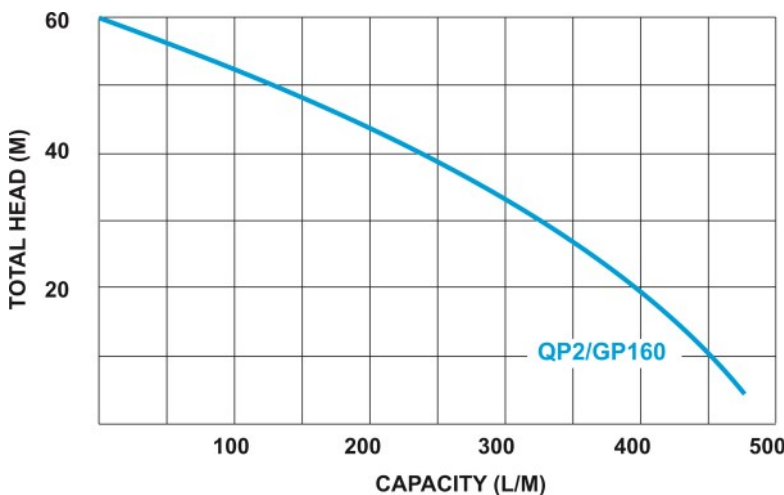

NEW Aussie Fire Cart ...

Convenient, safe, OH&S friendly
Trolley that suits GP160
Not assembled.
(pump sold separately)
s/code: QFIRECART



Rejuvenation kit

S/code
QP2S Q2SREJ