

ENCLOSED REELS

Alemite Enclosed Reels are ideal for when your workplace is in view of customers and a clean appearance is expected. These reels offer looks and performance to meet the needs of your shop. Placed together in a bank, Alemite Enclosed Reels feature a track system for easy installation.

FEATURES:

- Stain and impact resistant ABS polymer side panels
- Attractive casing for enhanced professional look
- Track system for quick and easy installation
- Roller guides attached to the hose reel for convenient servicing
- Compatibility – Oil, grease, air, water

INCLUDED ITEMS:

- Hose Reel
- Delivery Hose
- Hose Stop
- Union
- 24" (61 cm) Connecting Hose

ITEMS TO PURCHASE SEPARATELY:

- Cabinet
- End Panels



(shown as a bank
of cabinets with
end panels)

8079 Series

Oil

| Product # | Max Pressure | Delivery Hose | | | Connecting Hose ⁽¹⁾ | | Weight |
|-----------|---------------------|-----------------|-----------|---------|--------------------------------|----------|---------------|
| | | Specification | Part # | Outlet | Inlet | Part # | |
| 8079-C | 1,500 psi (103 bar) | 1/2" ID x 30 ft | 317813-30 | 1/2"(m) | 1/2"(m) | 317813-2 | 73 lb (33 kg) |
| 8079-D | 1,500 psi (103 bar) | 1/2" ID x 50 ft | 317813-50 | 1/2"(m) | 1/2"(m) | 317813-2 | 75 lb (34 kg) |

⁽¹⁾ Connecting Hose length is 24" (61 cm)

Grease

| Product # | Max Pressure | Delivery Hose | | | Connecting Hose ⁽¹⁾ | | Weight |
|-----------|---------------------|-----------------|-----------|---------|--------------------------------|----------|---------------|
| | | Specification | Part # | Outlet | Inlet | Part # | |
| 8079-A | 6,000 psi (413 bar) | 1/4" ID x 30 ft | 317874-30 | 1/4"(f) | 3/8"(m) | 317876-2 | 73 lb (33 kg) |
| 8079-B | 6,000 psi (413 bar) | 1/4" ID x 50 ft | 317874-50 | 1/4"(f) | 3/8"(m) | 317876-2 | 76 lb (35 kg) |

⁽¹⁾ Connecting Hose length is 24" (61 cm)

Air/Water

| Product # | Max Pressure | Delivery Hose | | | Connecting Hose ⁽¹⁾ | | Weight |
|-----------|------------------|-----------------|-----------|---------|--------------------------------|----------|---------------|
| | | Specification | Part # | Outlet | Inlet | Part # | |
| 8079-E* | 300 psi (20 bar) | 3/8" ID x 30 ft | 317803-30 | 1/4"(f) | 3/8"(m) | 317811-2 | 68 lb (30 kg) |
| 8079-F* | 300 psi (20 bar) | 3/8" ID x 50 ft | 317803-50 | 1/4"(f) | 3/8"(m) | 317811-2 | 70 lb (32 kg) |

⁽¹⁾ Connecting Hose length is 24" (61 cm)

* **⚠ WARNING** California Proposition 65: Cancer and reproductive harm. www.P65Warnings.ca.gov

ENCLOSED REELS

Bare Reels

| Product # | Usage | Max Pressure | Reel Inlet | Reel Outlet | Weight |
|-----------|-----------|---------------------|--------------|---------------------|---------------|
| 7335-D | Oil | 1,500 psi (103 bar) | 1/2" NPTF(f) | 1/2" NPTF(f) Swivel | 50 lb (23 kg) |
| 7334-D | Grease | 6,000 psi (413 bar) | 1/2" NPTF(f) | 3/8" NPTF(f) Swivel | 50 lb (23 kg) |
| 7336-D | Air/Water | 300 psi (20 bar) | 1/2" NPTF(f) | 3/8" NPTF(f) | 50 lb (23 kg) |

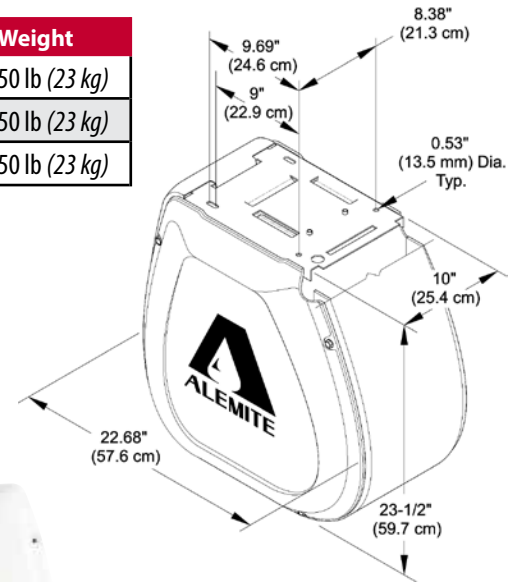

Cabinets

| Product # | Description | Weight |
|-----------|--|-------------------|
| 7331 | Enclosure Kit for 1 enclosed hose reel | 10.5 lb (4.75 kg) |
| 339371 | End panels for 1 bank of enclosed hose reels | 5.4 lb (2.45 kg) |
| 339368 | Strut for single reel installation | 0.5 lb (0.23 kg) |



7331



339371

IMPORTANT

When ordering enclosed reels, the cabinets and panels must be ordered separately as shown in the Cabinets table above. Order a separate cabinet for each reel. The reel product number only includes the reel and hose specified. It does not include the cabinet or panels.