

Polyflex Engine Mounts

ENGINE MOUNTS

Poly Flex mounts are designed as true PROPULSION ENGINE MOUNTS; with sufficient vertical deflection to obtain the desired Vibration Isolation, combined with minimum Fore & Aft and lateral deflection under the Propulsion Load and Incitial Loads due to sca conditions.

Our mounting systems cater for Marine, Defence, Agricultural, Mining & Industrial Applications and are long lasting and oil/fuel resistant.



Mount	Engines / Gensets
P#3.5F / CTF	1, 2, 3 Cylinder Gensets and Engines, Bukh, Beta, Nanni, Lombadini, etc. . .
P#4.5F / CTF	2, 3, 4 Cylinder Gensets and Engines, Mercruiser, Nanni, Perkins, Volvo, etc. . .
P#5.5F / CTF	Volvo, Kubota, Nanni, Lombadini, Ford, etc. . .
P#6.8F / CTF	Volvo, Cummins, Isuzu, Perkins, Ford, etc. . .
P#7.5F / CTF	Volvo, Cummins, Yanmar, Perkins Ford, Fiat Iveco, John Deere, etc. . .
P#8.5(5")F / CTF	Cummins, Caterpillar, Detroit, John Deere, MAN, MTU, etc. . .
P#8.5F / CTF	Cummins, Caterpillar, Fiat Iveco, Gardener, Nanni, Perkins, Ford, etc. . .
P##8.5F / CTF	Cummins, Caterpillar, Fiat Iveco, Gardener, Nanni, Perkins, Ford, etc. . .
P#8.8F / CTF	Yanmar, etc. . .
P#10.5F / CTF	Volvo, Caterpillar, Yanmar, Cummins, etc. . .
P#12.5F / CTF	Caterpillar, MTU, MAN, Cummins, Detroit, Fiat Iveco, Gardener, John Deere, etc. . .
P##12.5F / CTF	Caterpillar, MTU, MAN, Cummins, Detroit, Fiat Iveco, Gardener, John Deere, etc. . .
White Mounts	
P#12.5F	Caterpillar C32Acert
P##12.5F	Caterpillar C32Acert
Ci1050	Caterpillar C7 - C18 Marine Diesel
CiD1050	Caterpillar C7 - C18 Marine Diesel
Y#1CTF	IGM10
Y#1.5CTF	IGM10
Y#2CTF	2GM20, 2GM20F, 3GM30, 3GM30F, 3JH2BE, 3JH2TBE,3JH2TE, 4JH2BE, 4JH2TBE, 4JH2HTE, 4JH2DTE, 4JH2UTBE, 4JH2UTE, 4LHTE
Y#2.5CTF	2GM20, 2GM20F, 3GM30, 3GM30F, 3JH2BE, 3JH2TBE,3JH2TE, 4JH2BE, 4JH2TBE, 4JH2HTE, 4JH2DTE
Y#3CTF	4LHTE, 4LHDTE

Polyflex Engine Mounts



Poly Flex Engine Mounts: .5 & .8 CTF Series

Please Note:
Working loads stated are at 5.0mm static deflection for the range of hardnesses available N110+4:

1. An increased load will produce a larger static deflection.
2. In general the max. capacity of the mounts = 4 x Working Load.

Dimensions and Specifications are subjected to change without notice.
Data Sheets of axial, thrust and lateral load versus deflection are available on request from **Poly Flex** or any authorised distributor.

P#4.5CTF 60-15-16 (60) Illustrated

Dimensional Specifications:		Dimensions in (mm) unless otherwise stated										(Approx Shipping)	
Model	Working Load (kg) ¹	A	B	C	D	E	F	G	H	I	J (mm)	K	Weight (kg)
P#2.5CTF50-15-12	35-125	105	64	13	9	76.2 (3")	M12	50	-	14	83	102	0.4
P#2.5CTF50-15-14	35-125	105	64	13	9	76.2 (3")	M14	50	-	14	86.5	107	0.52
P#2.5CTF50-15-16	35-125	105	64	13	9	76.2 (3")	M16	50	-	14	88.5	109	0.52
P#3.5CTF60-15-12	50-150	119	71	-	10	90 (3 1/2")	M12	60	-	14	83	102	0.4
P#3.5CTF60-15-14	50-150	119	71	-	10	90 (3 1/2")	M14	60	-	14	86.5	107	0.52
P#3.5CTF60-15-16	50-150	119	71	-	10	90 (3 1/2")	M16	60	-	14	88.5	109	0.52
P#3.5CTF60-15-16L	50-150	119	71	-	10	90 (3 1/2")	M16	60	-	14	88.5	125	0.52
P#4.5CTF60-15-12	50-150	131	77.5	16	10.5	101.6 (4")	M12	60	-	14	83	102	0.4
P#4.5CTF60-15-14	50-150	131	77.5	16	10.5	101.6 (4")	M14	60	-	14	86.5	107	0.52
P#4.5CTF60-15-16	50-150	131	77.5	16	10.5	101.6 (4")	M16	60	-	14	88.5	109	0.52
P#4.8CTF60-15-12	50-150	151	103	16	10.5	120	M12	60	-	15	83.5	102	0.45
P#4.8CTF60-15-16	50-150	151	103	16	10.5	120	M16	60	-	15	77	109	0.67
P#4.8CTF60-15-16L	50-150	151	103	16	10.5	120	M16	60	-	15	77	132	0.84
P#4.9CTF60-15-12	50-150	155	77.5	16	10.5	125	M12	60	-	14	83	129	0.49
P#4.9CTF60-15-16	50-150	155	77.5	16	10.5	125	M16	60	-	14	83	136	0.48
P#5.5CTF65-20-16	75-150	137	84	23	11	105 (4 1/8")	M16	65	-	23	87	132	0.65
P#5.5CTF65-20-20	75-150	137	84	23	11	105 (4 1/8")	M20	65	-	23	94	172	0.7
P#6.5CTF73-20-16	100-200	164	87	20	13	127 (5")	M16	73	-	18	83	136	0.87
P#6.5CTF73-20-20	100-200	164	87	20	13	127 (5")	M20	73	-	18	88	151	0.96
P#6.8CTF80-20-16	125-250	164	98	20	13	127 (5")	M16	80	-	17	83	135	1.1
P#6.8CTF80-20-20	125-250	164	98	20	13	127 (5")	M20	80	-	17	89	135	1.26
P#6.8CTF80-20-24	125-250	164	98	20	13	127 (5")	M24	80	-	17	95	135	1.47
P#7.5CTF73-20-20	100-200	179	87	30	13	140 (5 1/2")	M16	73	-	17	81	136	0.88
P#7.5CTF73-20-20	100-200	179	87	30	13	140 (5 1/2")	M20	73	-	17	85	151	0.99
P#8.5CTF(5")90-30-20	175-300	193	107	25	14.5	127 (5")	M20	90	-	18.5	105	163	1.37
P#8.5CTF(5")90-30-24	175-300	193	107	25	14.5	127 (5")	M24	90	-	18.5	109	165	1.62
P#8.5CTF90-30-20	175-300	176	107	25	13.5	140 (5 1/2")	M20	90	-	17	105	163	1.37
P#8.5CTF90-30-24	175-300	176	107	25	13.5	140 (5 1/2")	M24	90	-	17	109	188	1.62
P#8.8CTF90-30-20	175-300	210	103	25	18.5	170	M20	90	-	17	105	188	2.16
P#8.8CTF90-30-24	175-300	210	103	25	18.5	170	M24	90	-	17	109	193	2.36
P#9.5CTF100-25-20	200-350	209	117	34	17	160	M20	100	-	18	99	161	1.94
P#9.5CTF100-25-24	200-350	209	117	34	17	160	M24	100	-	18	107	175	2.14
P#10.5CTF105-25-20	200-500	232	122	34	17	182	M20	105	-	18	99	161	1.9
P#10.5CTF105-25-24	200-500	232	122	34	17	182	M24	105	-	18	107	185	2
P#12.5CTF125-30-20	250-900	230	142	26	17	180 (7")	M20	125	-	19.5	104	173	2.32
P#12.5CTF125-30-24	250-900	230	142	26	17	180 (7")	M24	125	-	19.5	114	183	2.57
P#14.5CTF160-45-24	200-1075	330	200	135	22	270	M24	160	-	38	135	220	6.8
P#14.5CTF160-45-24A	200-1075	330	200	135	22	270	M24	160	-	38	133	212	6.8
P#14.5CTF160-45-30	200-1075	330	200	135	22	270	M30	160	-	38	142	242	7.8

Polyflex Engine Mounts

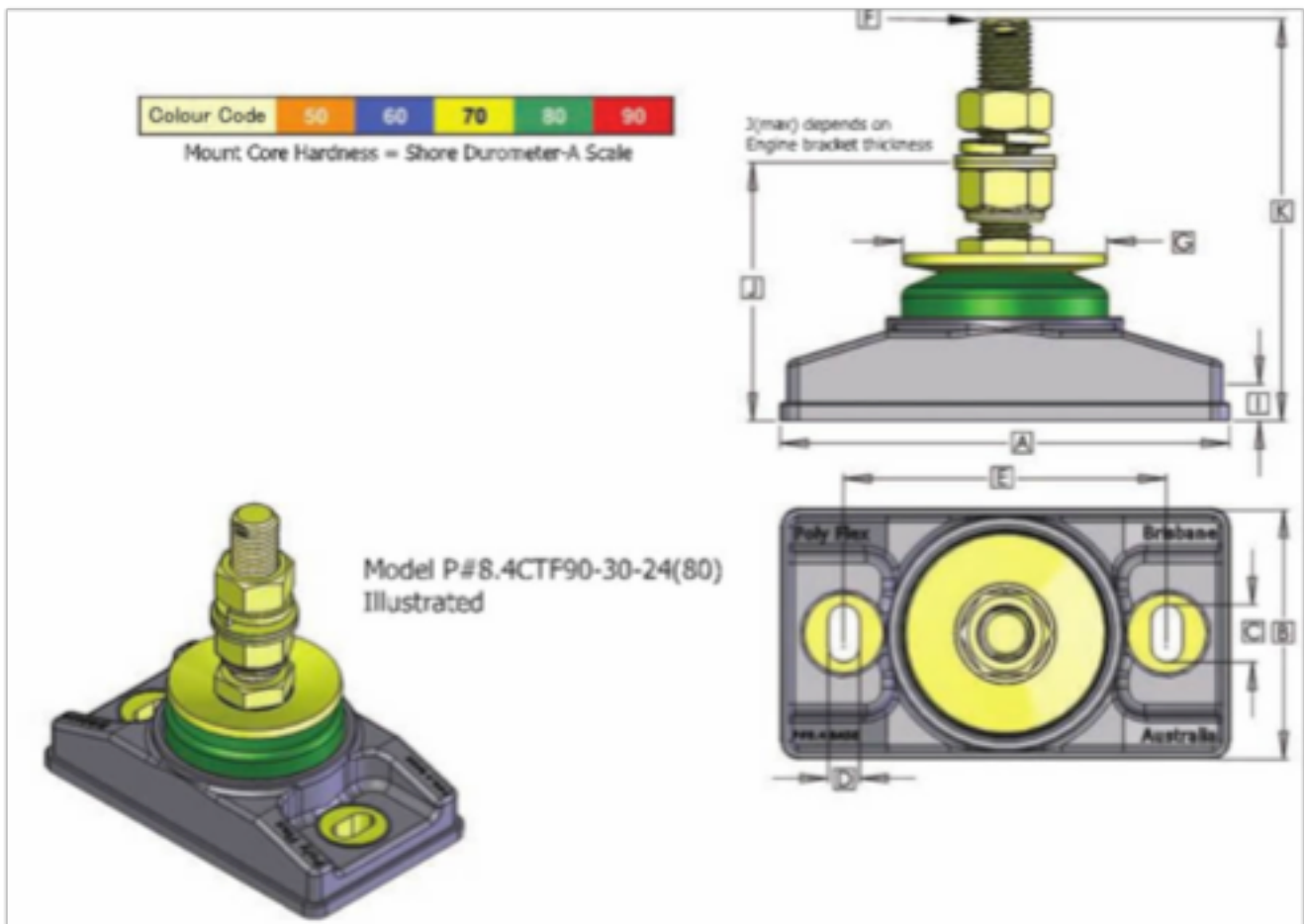

Dimensional Specifications:		Dimensions in (mm) unless otherwise stated										(Approx Shipping)	
Model	Working Load (kg) ¹	A	B	C	D	E	F	G	H	I	J (min)	K	Weight (kg)
P#5.4CTF65-20-16	75-150	150	80	15.5	10.5	100 - 4"	M16	65	-	15	83	130	0.86
P#5.4CTF65-20-20	75-150	150	80	15.5	10.5	100 - 4"	M20	65	-	15	89	142	1.05
P#6.4CTF73-20-16	100-200	180	96	19.5	13.5	127(5")	M16	73	-	15	85	135	0.96
P#6.4CTF73-20-20	100-200	180	96	19.5	13.5	127(5")	M20	73	-	15	94	150	1.1
P#7.4CTF80-20-16	125-250	193	96	19.5	13.5	140(5 1/2")	M16	80	-	15	83	135	1
P#7.4CTF80-20-20	125-250	193	96	19.5	13.5	140(5 1/2")	M20	80	-	15	87	143	1.2
P#8.4CTF90-30-20	175-300	193	107	25	14.5	140(5 1/2")	M20	90	-	18.5	105	163	1.37
P#8.4CTF90-30-24	175-300	193	107	25	14.5	140(5 1/2")	M24	90	-	18.5	109	165	1.615
P#8.4CTF90-30-24 Yw	175-300	193	107	25	14.5	140(5 1/2")	M24	90	-	18.5	109	165	1.62
P#9.4CTF100-25-20	200-350	230	120	25	17	160	M20	100	-	17	99	161	2
P#9.4CTF100-25-24	200-350	230	120	25	17	160	M24	100	-	17	107	175	2.15
P#10.4CTF105-25-20	200-500	250	124	25	17	182	M20	105	-	17	99	161	2.1
P#10.4CTF105-25-24	200-500	250	124	25	17	182	M24	105	-	17	107	165	2.3
P#12.4CTF125-30-20	250-900	230	142	26	17	180(7")	M20	125	-	19.5	104	173	2.32
P#12.4CTF125-30-24	250-900	230	142	26	17	180(7")	M24	125	-	19.5	111	183	2.57

Polyflex Engine Mounts

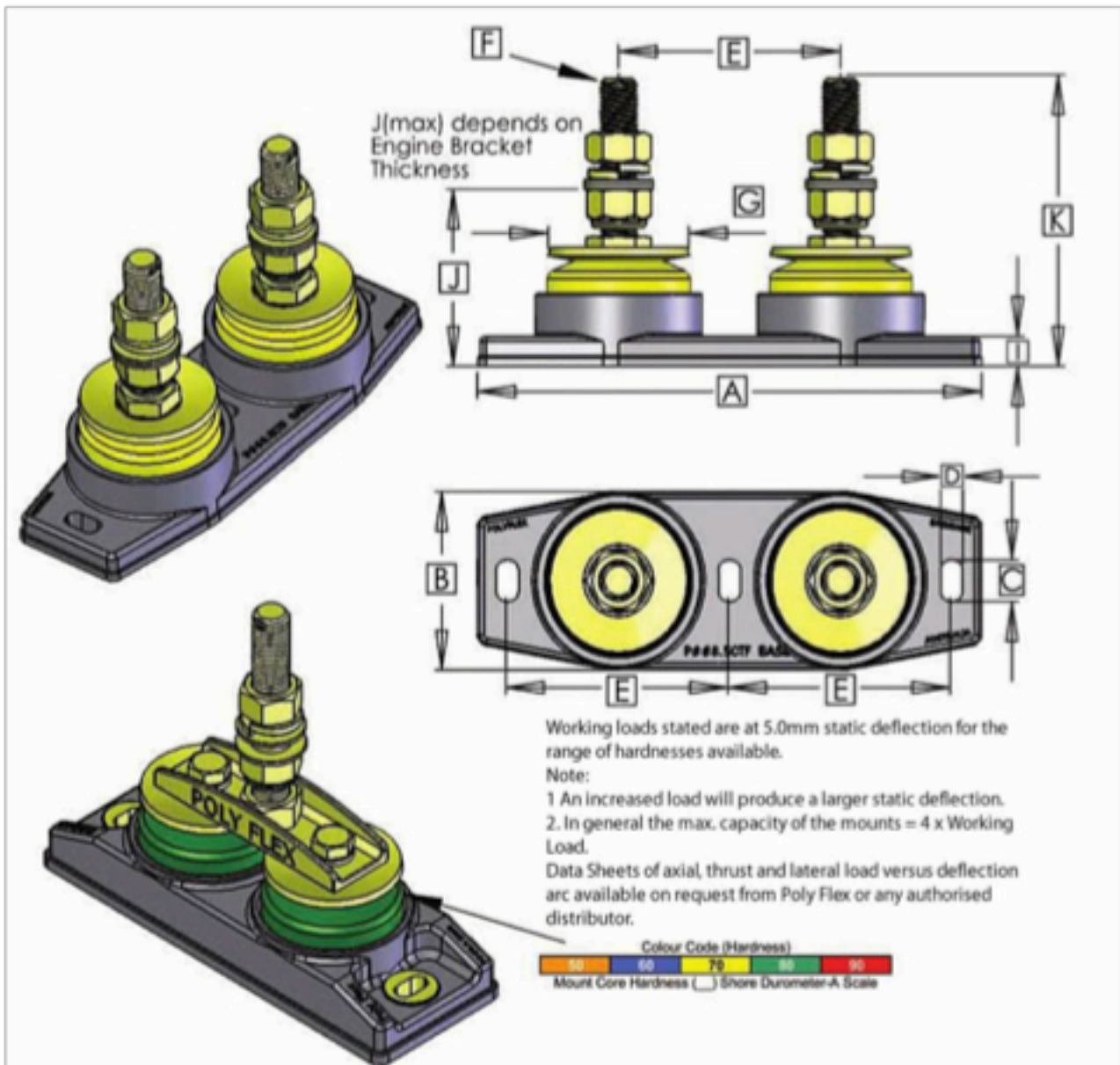

Dimensional Specifications:		Dimensions in (mm) unless otherwise stated										(Approx Shipping)	
Model	Working Load (kg) ¹	A	B	C	D	E	F	G	H	I	J (min)	K	Weight (kg)
PWB.4CTF90-30-20	350-600	302	107	25	14.5	250/110	M20	90	-	18.5	100	165	3.8
PWB.4CTF90-30-24	350-600	302	107	25	14.5	250/110	M24	90	-	18.5	110	170	3.8
PWB.4CTF90-30-20 Bridge Mount	350-600	302	107	25	14.5	250	M20	90	-	18.5	122	225	4.1
PWB.4CTF90-30-24 Bridge Mount	350-600	302	107	25	14.5	250	M24	90	-	18.5	132	200	4.1
PWB.5CTF90-30-20	350-600	316	107	25	13.5	140(S 1/2")	M20	90	-	17	106	163	2.8
PWB.5CTF90-30-24	350-600	316	107	25	13.5	140(S 1/2")	M24	90	-	17	106	165	3
PWF12.4CTF125-30-20	500-1800	416	141	26	17	350/155	M20	125	-	18.5	104	173	4.2
PWF12.4CTF125-30-24	500-1800	416	141	26	17	350/155	M24	125	-	18.5	111	183	4.5
PWF12.5CTF125-30-20	500-1800	410	142	26	17	180(7")	M20	125	-	19.5	104	173	4.5
PWF12.5CTF125-30-24	500-1800	410	142	26	17	180(7")	M24	125	-	19.5	114	183	4.5

Polyflex Engine Mounts

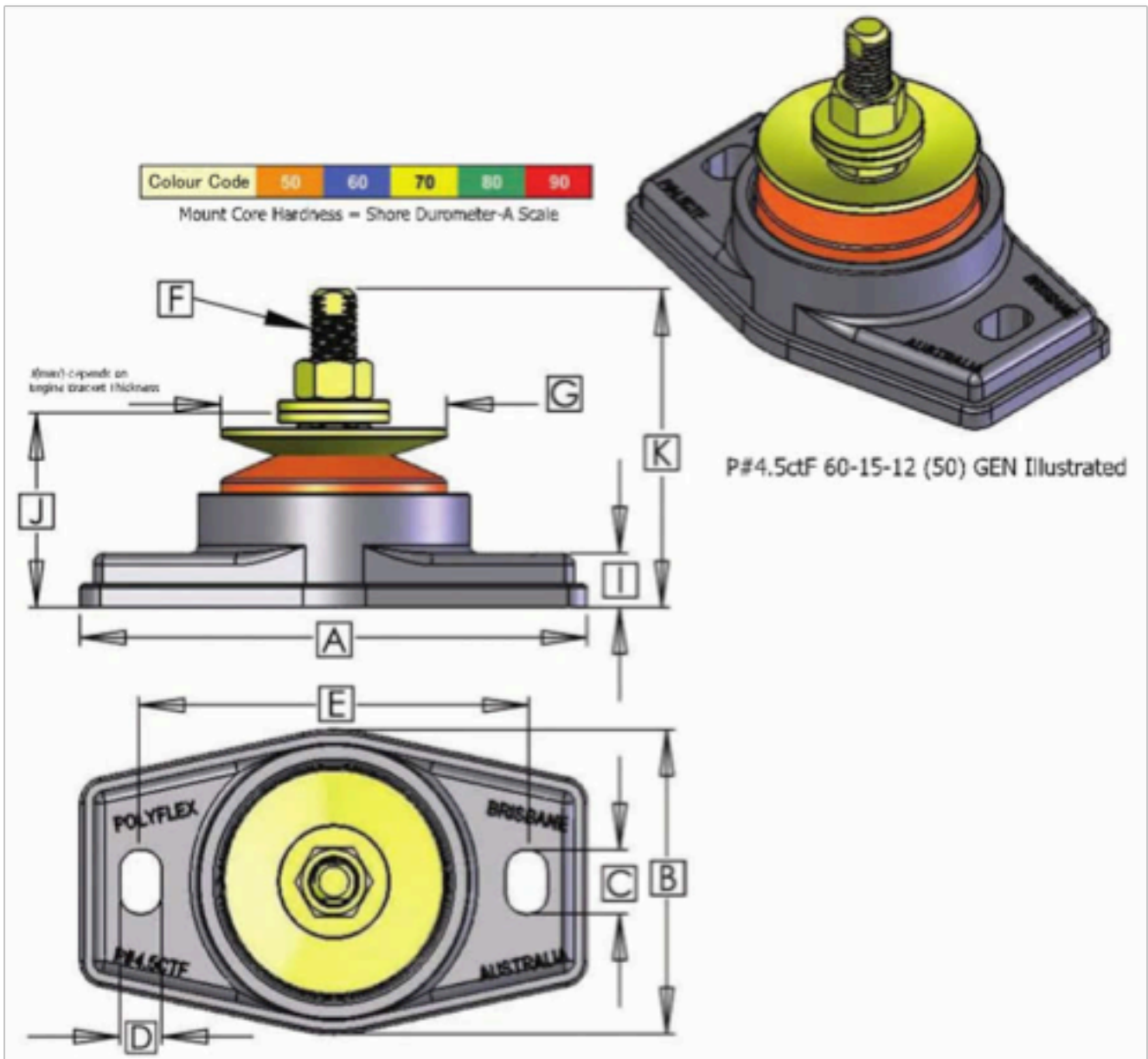

Dimensional Specifications:		Dimensions in (mm) unless otherwise stated										(Approx Shipping)	
Model	Working Load (kg)*	A	B	C	D	E	F	G	H	I	J (min)	K	Weight (kg)
P#2.5CTF50-15-12GEN	35-125	105	64	13	9	78.2(3")	M12	50	49	14	-	95	0.4
P#3.5CTF60-15-12GEN	50-150	119	71	-	10	90(3 1/2")	M12	60	49	14	-	95	0.4
P#4.5CTF60-15-12GEN	50-150	131	77.5	16	10.5	101.6(4")	M12	60	49	14	-	95	0.4
P#5.5CTF65-20-16GEN	75-150	137	84	23	11	105(4 1/8")	M16	65	68	18	-	125	0.645
P#6.5CTF73-20-16GEN	100-200	164	87	20	13	127(5")	M16	73	68	18	-	125	0.865
P#6.8CTF80-20-20GEN	125-250	164	96	20	13	127(5")	M20	80	70	17	-	125	0.95
P#7.5CTF73-20-16GEN	100-200	179	87	30	13	140(5 1/2")	M16	73	67	17	-	125	0.88
P#8.5CTF90-30-20GEN	175-300	176	107	25	13.5	140(5 1/2")	M20	90	80	17	-	143	1.37
P#10.5CTF105-25-20GEN	200-450	232	122	34	17	182	M20	105	83	18	-	146	1.895