



## COMPACT REELS

Alemite Compact Reels provide optimum performance and safety in rough working environments. Featuring the same mounting pattern as Alemite's Heavy Duty and Severe Duty Reels, these models are engineered for use in locations where space is limited. Alemite Compact Reels utilize shorter arms and a smaller diameter to provide reel performance in tight spaces.

### FEATURES:

- Saves space; fits in cabinets with 16.5" depth
- Superior Performance – Swivel and reel ball bearings reduce torque load on power spring for smooth retraction every time
- Anti-Lockout Design – Ratchet prevents lockup when hose is fully extended, eliminating the need to manually release the pawl at the reel
- Corrosion Resistant – Sealed bearings prevent contamination and minimize maintenance, a critical performance factor in dirty environments
- Easy Installation and Maintenance – Factory lubricated one piece power spring cassette makes installation and maintenance safe and easy
- Durable – Heavy metal arbor design withstands extreme stress and eliminates breakage associated with non-metal and light weight metal arbors
- Adjustable and Versatile – 5 position guide arm allows hose to release at an optimum position. Narrow design allows for efficient use of available space

### INCLUDED ITEMS:

- Hose Reel
- Hose
- Hose Stop
- Union
- 24" (61 cm) Connecting Hose



8016-B



8017-K

## Oil

Product #	Color	Max Pressure	Delivery Hose			Connecting Hose		Weight
			Specification	Part #	Outlet	Inlet	Part #	
8016-C	Maroon	1,500 psi (103 bar)	1/2" ID x 30 ft	317813-30	1/2" NPTF(m)	1/2" NPTF(m)	317813-2	53 lb. (24 kg)

Includes narrow bare reel 7316-C

## Grease

Product #	Color	Max Pressure	Delivery Hose			Connecting Hose		Weight
			Specification	Part #	Outlet	Inlet	Part #	
8016-B	Maroon	6,000 psi (413 bar)	1/4" ID x 50 ft	317874-50	1/4" NPTF(f)	3/8" NPTF(m)	317876-2	53 lb. (24 kg)

Includes narrow bare reel 7316-B

## COMPACT REELS

### Air/Water

Product #	Color	Max Pressure	Delivery Hose			Connecting Hose		Weight
			Specification	Part #	Outlet	Inlet	Part #	
8016-F*	Maroon	300 psi (21 bar)	3/8" ID x 50 ft	317803-50	1/4" NPTF(m)	1/2" NPTF(m)	317811-2	53 lb. (24 kg)

Includes narrow bare reel 7316-F

\* **⚠ WARNING** California Proposition 65: Cancer and reproductive harm. [www.P65Warnings.ca.gov](http://www.P65Warnings.ca.gov)

### Diesel Fuel Oil/Evacuation

Product #	Color	Max Pressure	Delivery Hose			Connecting Hose		Weight
			Specification	Part #	Outlet	Inlet	Part #	
8017-K	Maroon	300 psi (21 bar) 30" Hg	3/4" ID x 30 ft	317868-30	3/4" NPTF(m)	3/4" NPTF(m)	317868-2	73 lb. (33 kg)

Includes wide bare reel 7317-K

### Bare Reels

Product #	Color	Usage	Max Pressure	Reel Inlet	Reel Outlet	Weight
7316-C	Maroon	Oil	1,500 psi (103 bar)	1/2" NPTF(f)	3/8" NPSM(f) Swivel	43 lb. (19,5 kg)
7316-B	Maroon	Grease	6,000 psi (413 bar)	1/2" NPTF(f)	3/8" NPSM(f) Swivel	43 lb. (19,5 kg)
7316-F*	Maroon	Air/Water	300 psi (21 bar)	1/2" NPTF(f)	1/4" NPSM(f) Swivel	43 lb. (19,5 kg)
7317-K	Maroon	Oil/Air/Water/ Diesel Fuel Oil	300 psi (21 bar) / 30" Hg	3/4" NPTF(f)	3/4" NPSM(f) Swivel	58 lb. (26 kg)

\* **⚠ WARNING** California Proposition 65: Cancer and reproductive harm. [www.P65Warnings.ca.gov](http://www.P65Warnings.ca.gov)

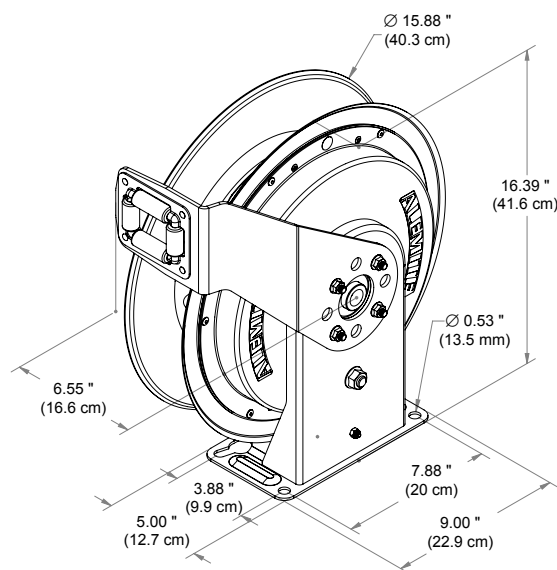

**7316-C**

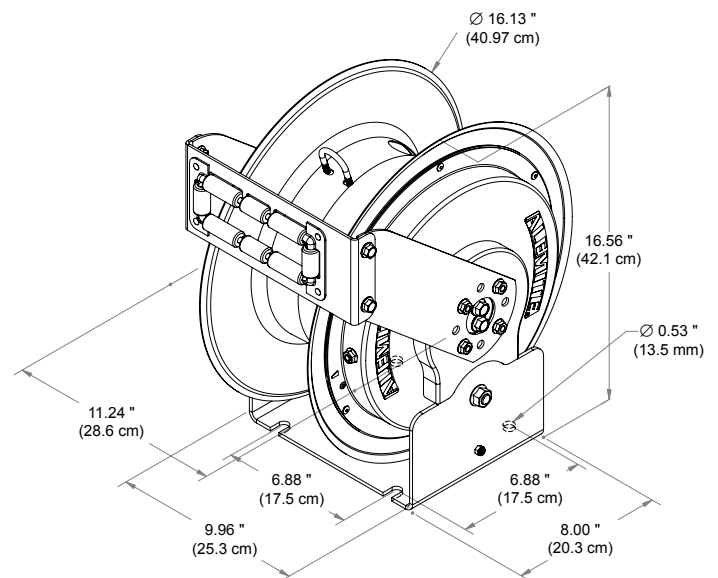

**7317-K**