

THREADED FITTINGS

1/4" PTF Fittings

Alemite 1/4" PTF Fittings are widely used for larger bearings on farm machinery and heavy industrial equipment. Recommended for heavy lubricants in cold weather.

FEATURES:

- Exceeds 72 hour salt spray test
- Dirt excluding check ball
- Trivalent zinc plating
- RoHS compliant
- Dry seal eliminates need for sealant

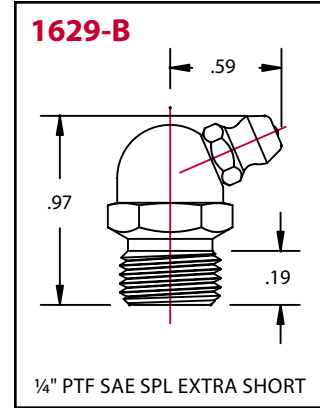
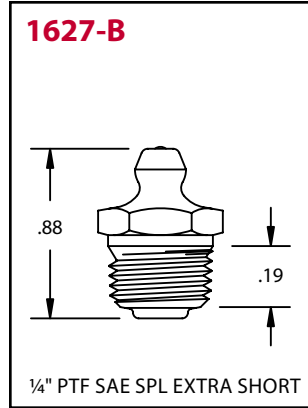

Product #	Type	Hex Size	Overall Length	Shank Length
1627-B	Straight	9/16"	7/8"	27/64"
1629-B	67.5°	9/16"	31/32"	11/32"