

INDUSTRIAL LUBRICATION FITTINGS

LEAKPROOF FITTINGS

To improve reliability of the check valve in these fittings, keep input passages free of foreign particles. Redundancy of seal should be provided in critical applications where back pressure must be maintained.

Threaded

RECOMMENDED ACCESSORY:

- Dust Caps

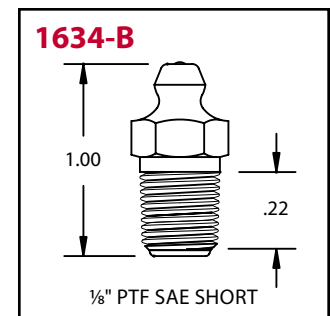
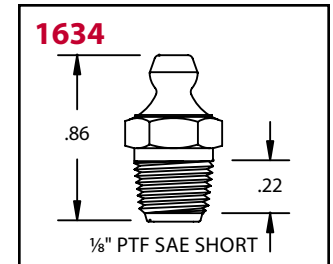
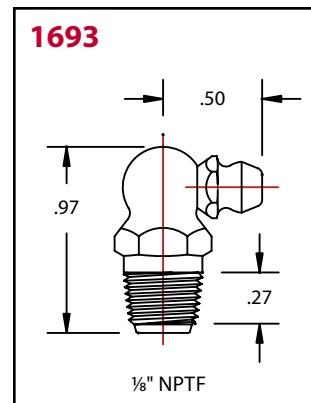
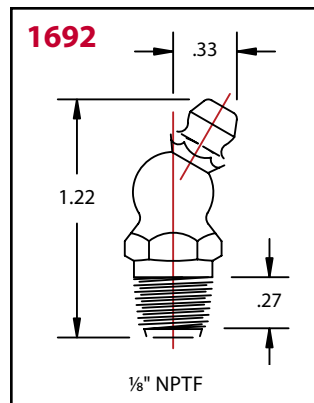
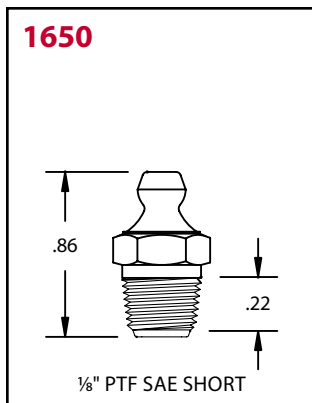

Product #	Type	Thread	Hex Size	Overall Length	Shank Length	Check Valve	Max. Back Pressure
1650 ⁽¹⁾	Straight	1/8" PTF SAE Short	7/16"	29/32"	25/64"	Fluoroelastomerer Ball	3,000 psi
1692 ⁽¹⁾	30°	1/8" NPTF	7/16"	1-7/32"	25/64"	Buna-N disk	3,000 psi
1693 ⁽¹⁾	90°	1/8" NPTF	7/16"	31/32"	25/64"	Buna-N disk	3,000 psi
1634 ⁽²⁾	Straight	1/8" PTF SAE Short	7/16"	27/32"	23/64"	Steel Ball/Brass Seat	10,000 psi
1634-B ⁽²⁾	Straight	1/8" PTF SAE Short	7/16"	1"	33/64"	Steel Ball/Brass Seat plus dirt excluding surface ball check	10,000 psi

⁽¹⁾ Designed for light oils

⁽²⁾ Designed for grease, medium and heavy oils

Drive

Product #	Type	Thread	Press Fit OD	Overall Length	Check Valve	Max Back Pressure
369533	Straight	—	7/16"	55/64"	Steel Ball/Brass Seat	*

* Maximum pressure depends on the press fit

