

SURE FOOT ISOLATORS

Mackay Sure Foot Levelling Isolators are designed for cost-effective machine levelling for isolator loads up to 6000Kg. Sure Foot Levelling Isolators offer an effective and durable method for isolating free standing equipment and machinery on non-level surfaces.

Sure Foot standard range is made with electrolytically plated zinc applied to automotive standards. Where superior corrosion resistance is required Mackay recommends the Sure Foot stainless Steel alternative. Made using Nitrile rubber, Sure Foot offers superior chemical and oil resistance in comparison to natural rubber

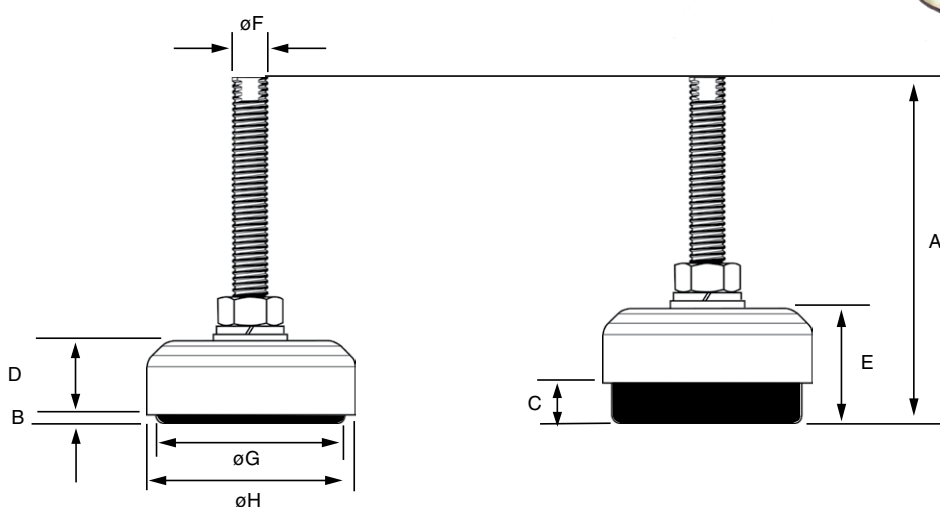
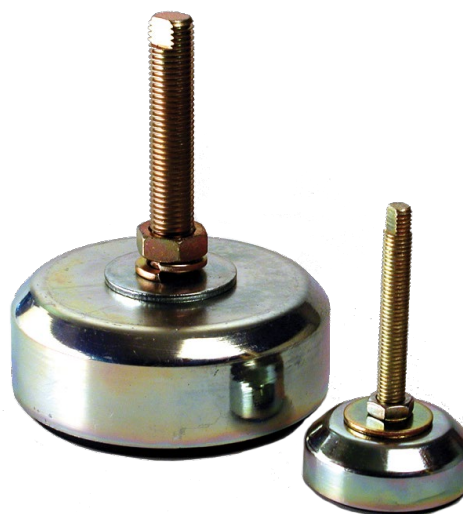

DIMENSIONS

Part No.		OVERALL	EXPOSED BASE		ADJUSTMENT		DIAMETERS		
Standard	Stainless type 304	A mm	Min B mm	Max C mm	Min D mm	Max E mm	Thread F mm	Base G mm	Cap H mm
M400300	M410300	119	6.7	15	31.7	40	(M12x1.75)	64	71
M401200	M411200	144	8.8	28	50.8	70	(M16x2.0)	91	101
M402500		177	11.9	32	61.9	82	(M20x2.5)	135	144
M404000		212	14.9	40	74.9	100	(M24x3.0)	180	192
M406000		218	14.9	46	80.9	112	(M24x3.0)	203	216

PROPERTIES

Part No.		LOAD RANGE		DEFLECTION AT MAX EXPOSED BASE		Weight kg
Standard	Stainless type 304	Min kg	Max kg	Min Load mm	Max Load mm	
M400300	M410300	30	300	0.2	2.3	0.4
M401200	M411200	300	1200	1.5	5.9	1.1
M402500		1200	2500	3.0	6.3	2.5
M404000		2500	4000	4.1	6.5	5.2
M406000		4000	6000	6.5	9.7	6.4

All properties nominal, contact Mackay for Technical advice All Dimensions in Millimetres